



US 20080238303A1

(19) **United States**

(12) **Patent Application Publication**

**LEE et al.**

(10) **Pub. No.: US 2008/0238303 A1**

(43) **Pub. Date: Oct. 2, 2008**

(54) **ORGANIC LIGHT EMITTING DISPLAY DEVICE HAVING DESICCANT LAYER AND METHOD OF MANUFACTURING THE SAME**

**Publication Classification**

(51) **Int. Cl.**  
*H01L 27/28* (2006.01)  
*H01J 9/02* (2006.01)

(76) Inventors: **Dong-Won LEE**, Seongnam-si (KR); **Hoon Kim**, Hwaseong-si (KR); **Won-Hoe Koo**, Suwon-si (KR); **Sang-Woo Lee**, Suwon-si (KR); **Jung-Mi Choi**, Yongin-si (KR)

(52) **U.S. CL.** ..... 313/504; 445/24

(57) **ABSTRACT**

An organic light emitting display device includes: an organic light emitting pixel unit having a first electrode, an organic light emitting layer, and a second electrode, formed on a substrate; where a first anti-moisture protective layer is formed on the upper surface of the second electrode; and a second anti-moisture protective layer is formed on the upper surface of the first protective layer, where the second protective layer includes desiccant particles of diameters including a predetermined maximum diameter and where the first protective layer is substantially devoid of desiccant particles having the predetermined maximum diameter or larger, and the first protective layer has a thickness substantially greater than the predetermined maximum diameter.

Correspondence Address:  
**MACPHERSON KWOK CHEN & HEID LLP**  
2033 GATEWAY PLACE, SUITE 400  
SAN JOSE, CA 95110 (US)

(21) Appl. No.: **12/014,459**

(22) Filed: **Jan. 15, 2008**

(30) **Foreign Application Priority Data**

Mar. 30, 2007 (KR) ..... 10-2007-0031427

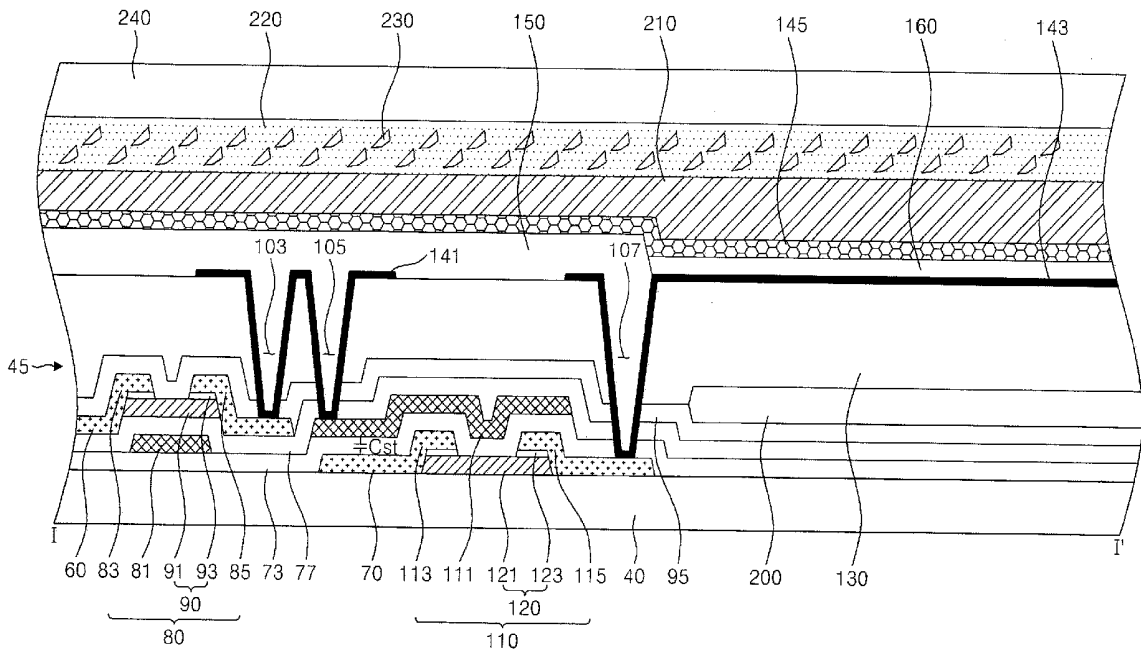

FIG. 1

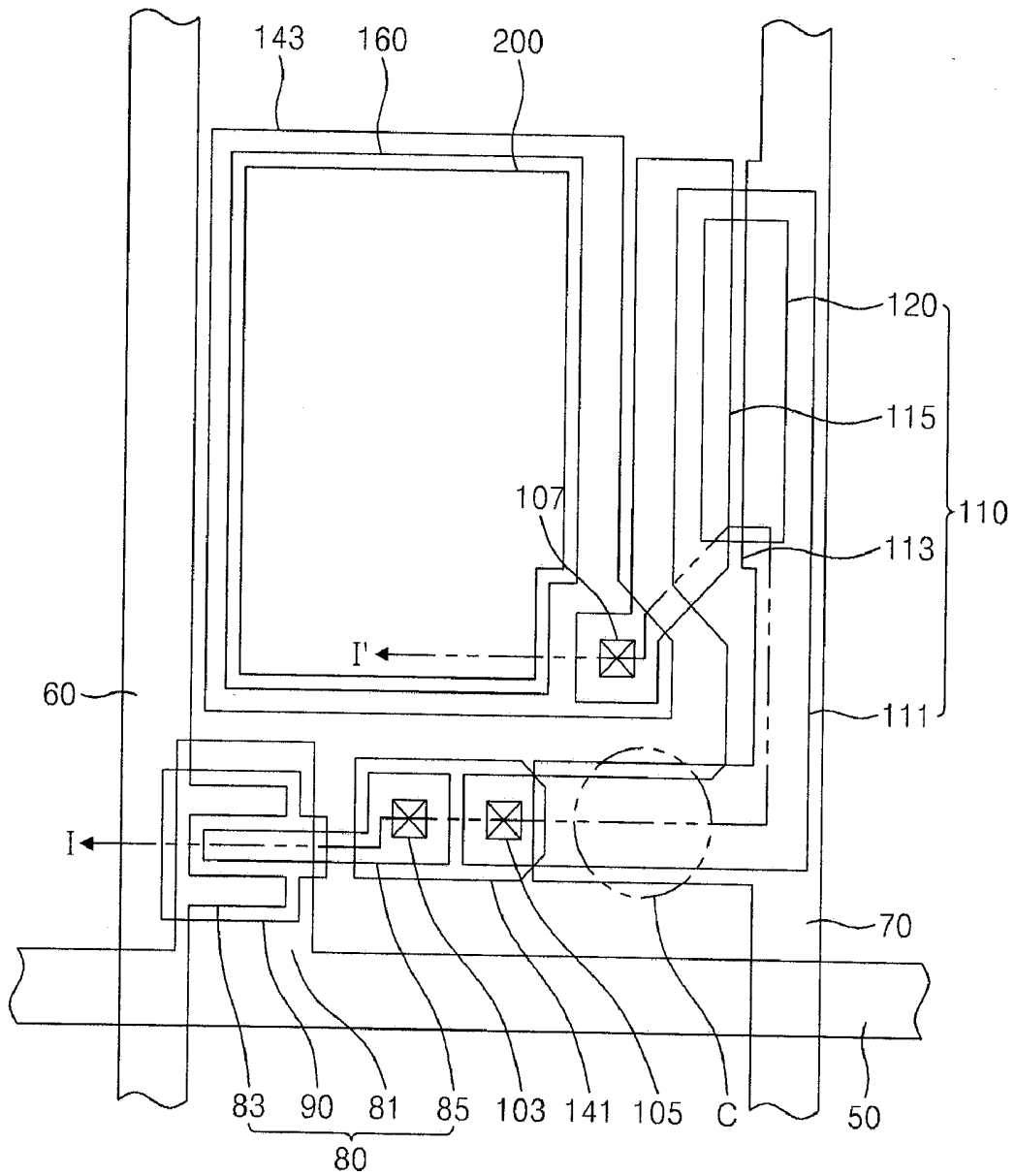

FIG. 2

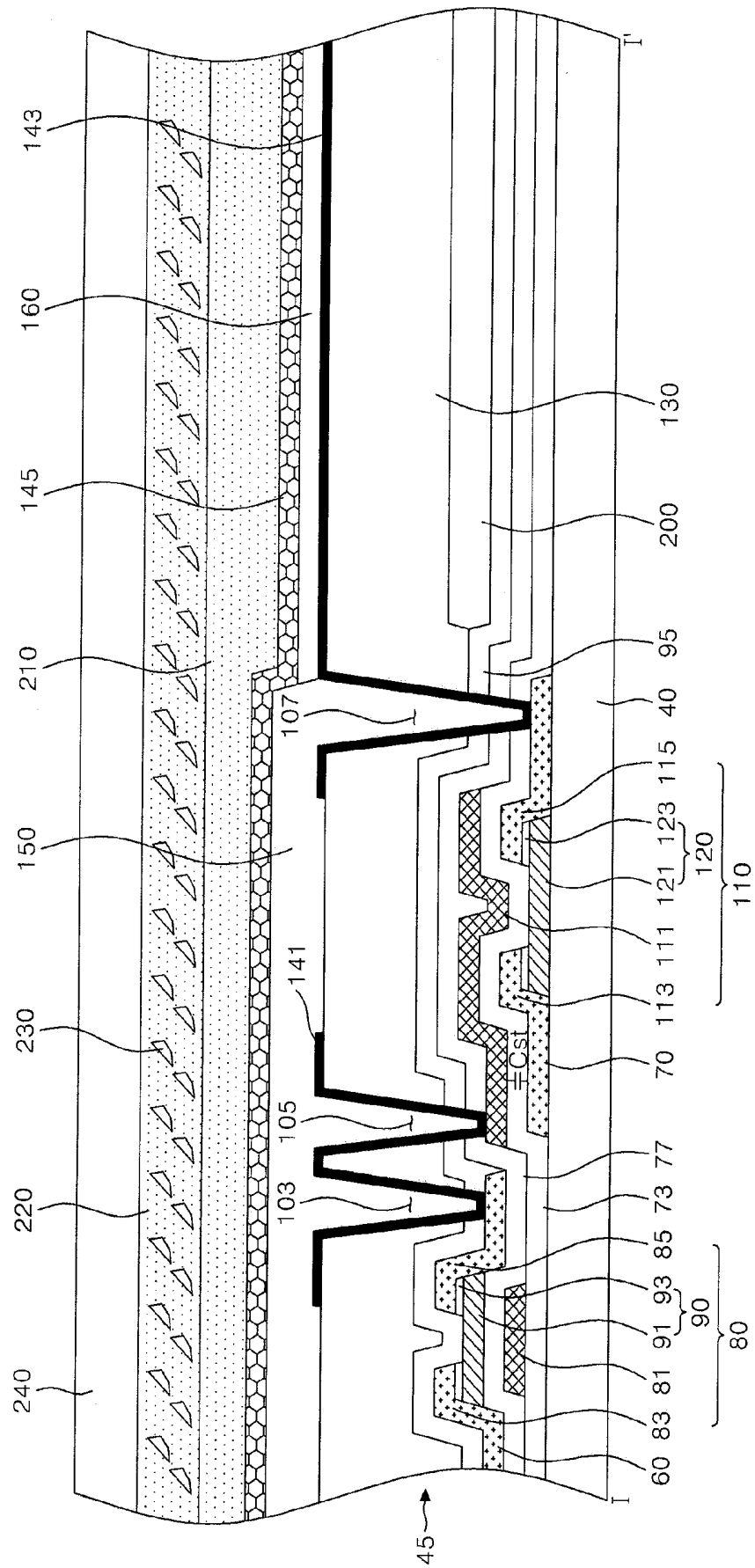



FIG. 4

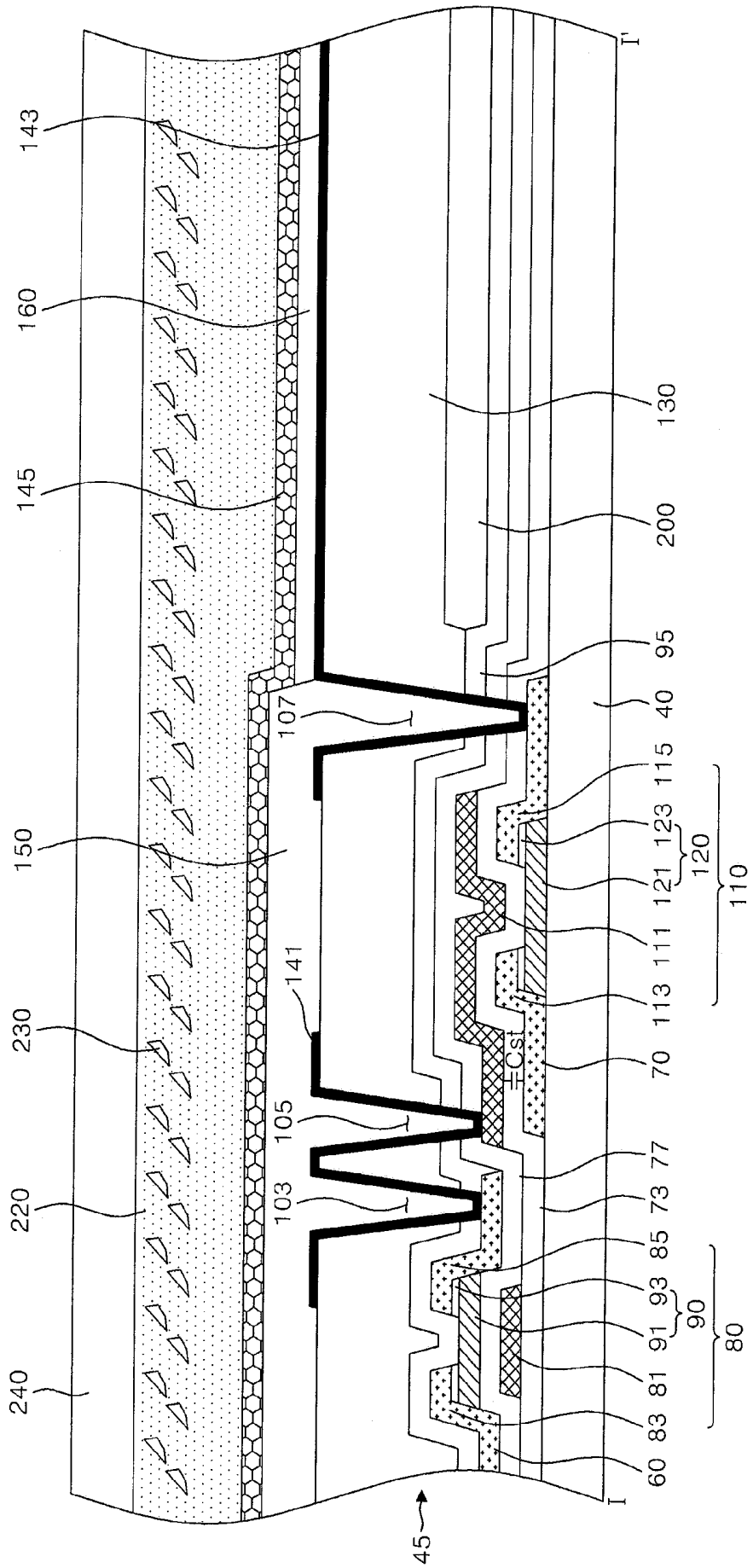

FIG. 5A

45

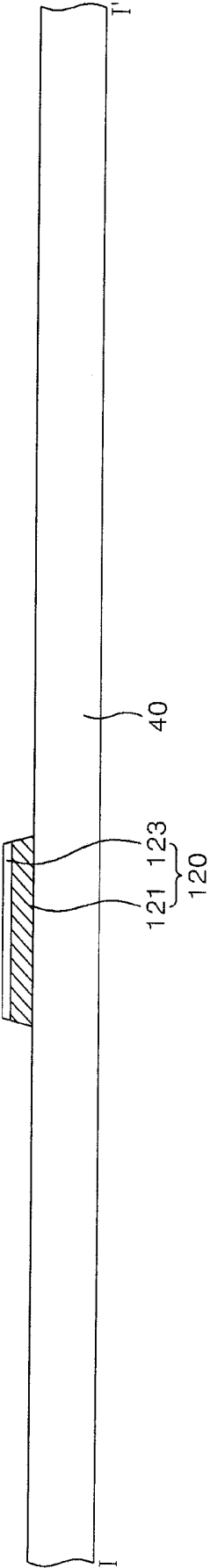

FIG. 5B

45

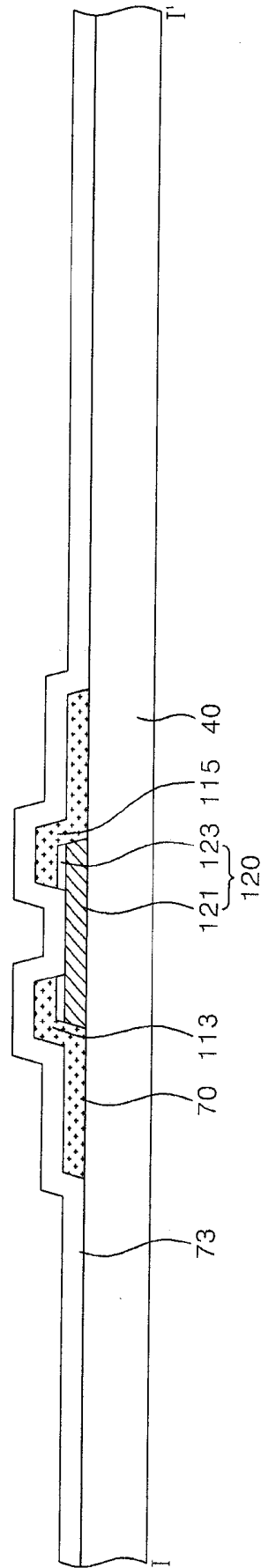

FIG. 5C

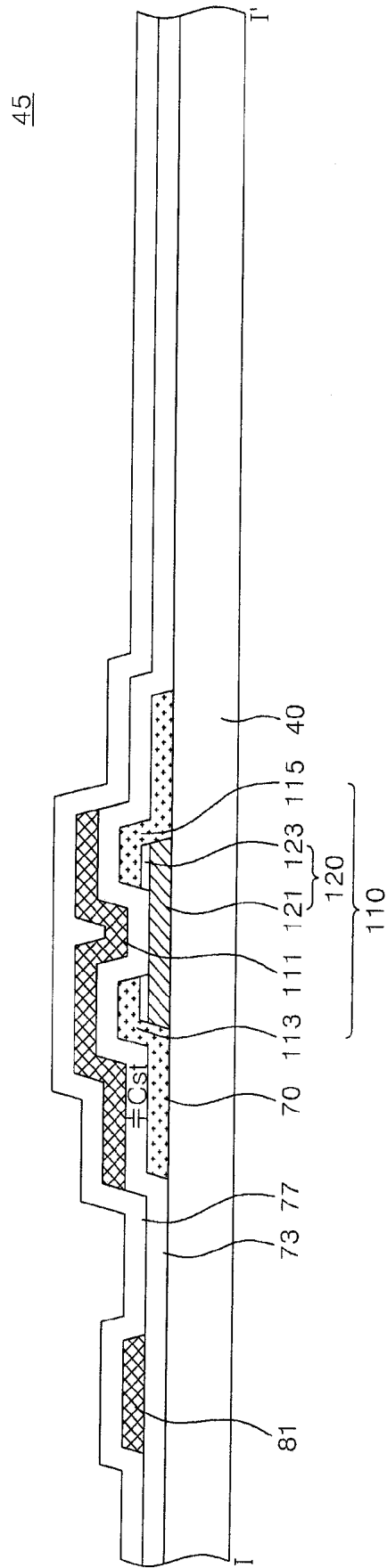

FIG. 5D

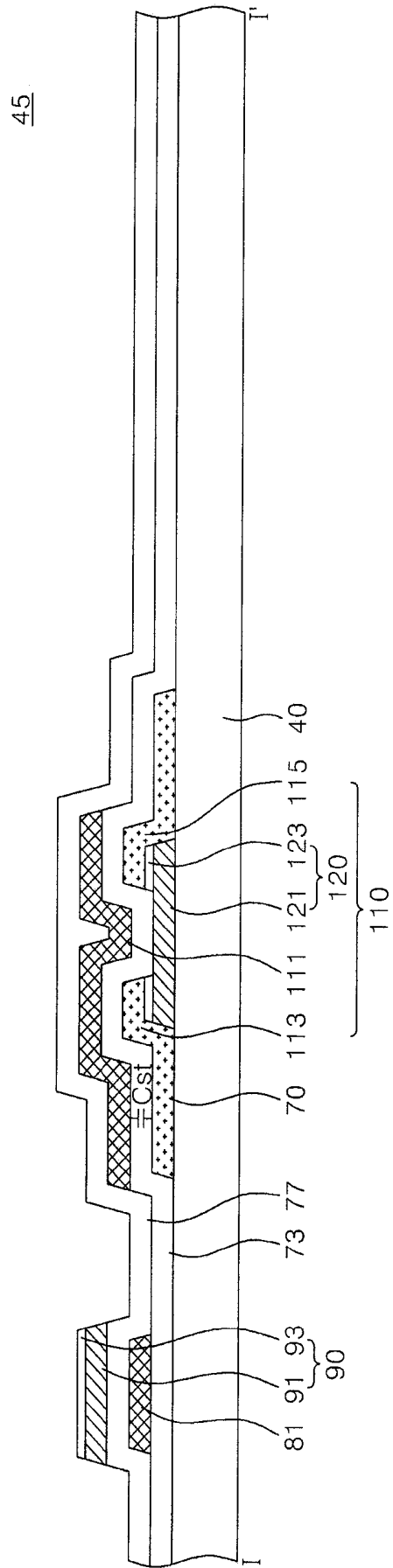

FIG. 5E

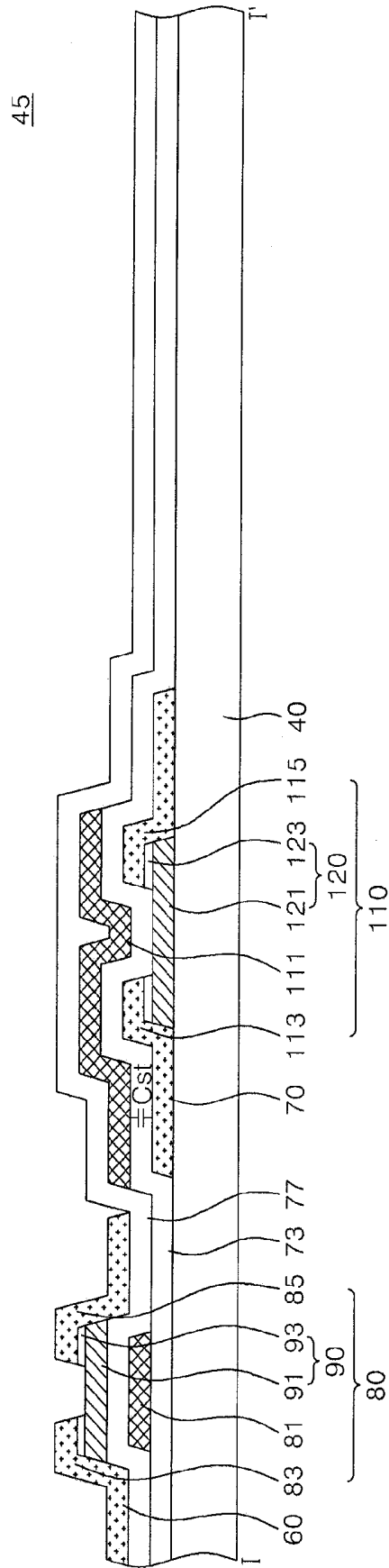



FIG. 5G

45

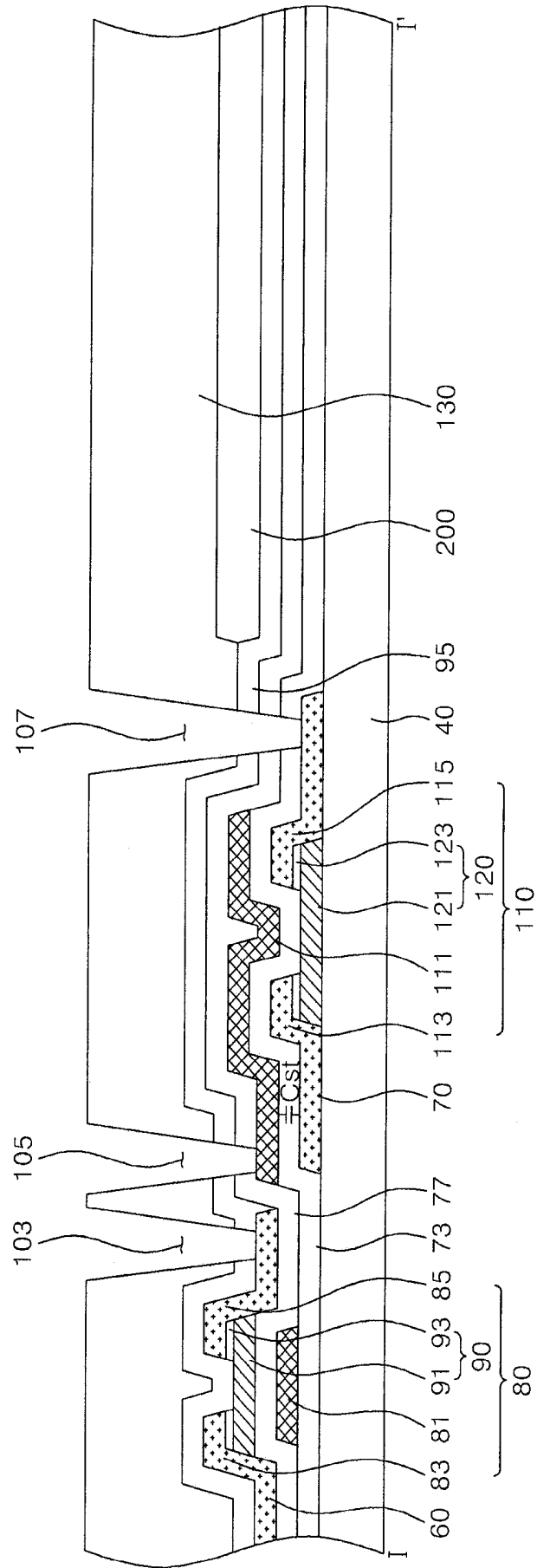
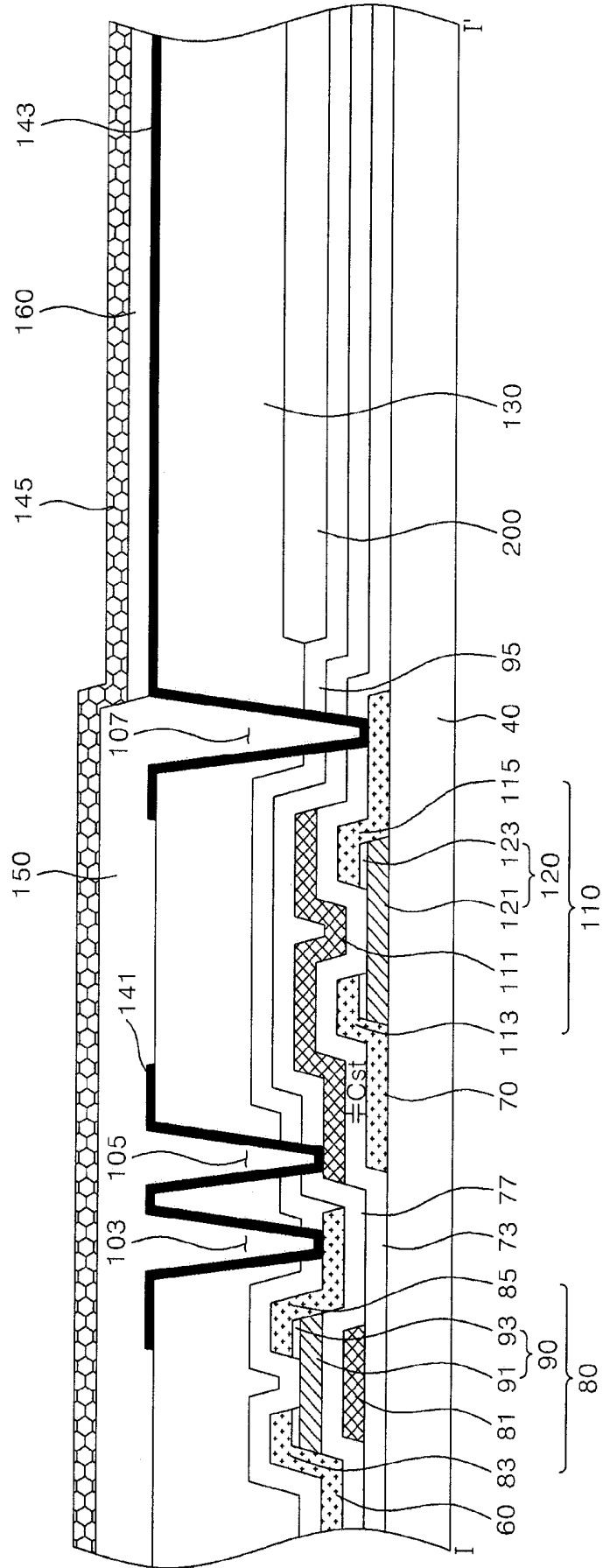





FIG. 5J

45









**ORGANIC LIGHT EMITTING DISPLAY  
DEVICE HAVING DESICCANT LAYER AND  
METHOD OF MANUFACTURING THE SAME**

**CROSS-REFERENCE TO RELATED  
APPLICATION**

[0001] This application claims priority from Korean Patent Application No. 10-2007-0031427, filed on Mar. 30, 2007, the disclosure of which is incorporated herein by reference in its entirety.

**BACKGROUND**

[0002] 1. Field of Disclosure

[0003] The present disclosure of disclosure relates to an organic light emitting display (OLED) device and, more particularly, to an organic light emitting display device having a desiccant layer and to methods of manufacturing the same.

[0004] 2. Description of Related Technology

[0005] One of the core technologies in the information and communication era is that of an image display device which can display a variety of information on a user-viewable screen. A general desire in the technology is to develop improved display devices that are thinner, lighter, more portable, more reliable and provide higher performance than preceding generations of devices. Accordingly, various flat panel display devices, including organic light emitting display (OLED) devices are being developed to reduce weight and volume, which are drawbacks of the older cathode ray tube (CRT) technologies.

[0006] In a classic OLED device, electrons and holes are respectively injected from an electron injection electrode (cathode) and a hole injection electrode (anode) into an emissive layer. The injected charge carriers combine with each other in the emissive layer and generate excitons, where the excitons emit light while transitioning from an excited energy state to a ground state.

[0007] When compared against competing flat panel technologies, OLED devices offer advantages such as low driving voltage, low power consumption, light weight, and natural color display. However they also have the problem of a comparatively shorter lifespan. One of the factors affecting the lifespan of the OLED device is oxidation due to permeation of oxygen and/or moisture into the device.

[0008] A conventional OLED device comprises an organic light emitting pixel unit having a thin film transistor (TFT), an electron injection electrode, an organic light emitting layer, and a hole injection electrode, where these are integrally formed on a substrate. An anti-moisture protective layer is provided for protecting the organic light emitting pixel unit moisture, and a protective substrate is bonded to the substrate.

[0009] The anti-moisture protective layer includes desiccant particles of varying diameters for removing or retaining moisture that manages to permeate into the device from the outside. The anti-moisture protective layer is formed on the overall surface of the substrate to increase the lifespan of the organic light emitting pixel unit. In this case, due to their variations in size, the desiccant particles can cause spot depressions in an underlying layer due to the pressure exerted from the top when the substrate is bonded to the anti-moisture protective substrate. The spot depressions of the underlying layer can cause an electrical failure in which the electron injection electrode is shorted into contact with the hole injection electrode due to the pressurization of desiccant particles,

thus resulting in a pixel defect in which the organic light emitting pixel unit does not emit light.

**SUMMARY**

[0010] The present disclosure of disclosure provides an organic light emitting display (OLED) device and a method of manufacturing the organic light emitting display device in a manner which prevents or reduces the likelihood of formation of spot depressions and deformations of electrodes due to presence of desiccant particles near such locations and thus prevents a pixel defect due to the undesirable shorting contact between the electron injection electrode and the hole injection electrode of the pixel units in the OLED device.

[0011] In one exemplary embodiment, an organic light emitting display (OLED) device includes: an organic light emitting pixel unit having a first electrode, an organic light emitting layer, and a second electrode, formed on a substrate; a first protective layer that is substantially free of any desiccant particles where the first protective layer is formed on an upper surface of the second electrode; and where a second protective layer that includes desiccant particles is thereafter formed on the first protective layer. The first protective layer is composed of a sealant material with sufficient elasticity or plasticity to thus act as a buffer against spot depressions caused by compression of desiccant particles present in the second protective layer.

[0012] The organic light emitting display device may further include a protective substrate that is compressively bonded to the second protective layer.

[0013] The first protective layer may be formed of a sealant.

[0014] The second protective layer including the desiccant particles may also be formed of a sealant.

[0015] The sealant material of the second protective layer may include a same sealant material as used in the first protective layer. For example, the sealant of the second protective layer may be formed of a same epoxy-based resin as the sealant of the first protective layer.

[0016] The sealant of the second protective layer may be formed of a different material from that of the sealant of the second protective layer. For example, the sealant of the second protective layer may be formed of a different epoxy-based resin from that of the first protective layer.

[0017] The first protective layer should be formed with a thickness greater than the largest normal diameters of the desiccant particles.

[0018] The desiccant particles may be formed of at least one of a talc and a silica gel.

[0019] In one exemplary embodiment, an organic light emitting display device includes: an organic light emitting diode, including a first electrode, an organic light emitting layer, and a second electrode, formed on a substrate; and a protective layer, including desiccant particles, formed on the upper surface of the second electrode, wherein the desiccant particles are spaced apart at least 5  $\mu\text{m}$  above the upper surface of the second electrode.

[0020] The organic light emitting display device may further include a protective substrate bonded to the substrate with the protective layer disposed therebetween.

[0021] In one exemplary embodiment, a method of manufacturing an organic light emitting display device includes: forming an organic light emitting pixel unit on a substrate, the organic light emitting pixel unit including a driving thin film transistor, a switching thin film transistor, a first electrode, an organic light emitting layer, and a second electrode, forming

a first protective layer on the upper surface of the organic light emitting pixel unit; and forming a second protective layer in which desiccant particles are distributed on the upper surface of the first protective layer.

[0022] The process of forming the organic light emitting pixel unit may include: forming the driving thin film transistor and the switching thin film transistor on the substrate; forming a passivation layer to cover the driving thin film transistor and the switching thin film transistor, and a color filter on the upper surface of the passivation layer; forming a planarization layer including first to third contact holes on the upper surface of the passivation layer and the color filter; forming a transparent conductive pattern including a connection electrode and the first electrode on the upper surface of the planarization layer; forming a barrier layer on the upper surface of the planarization layer and the connection electrode, and the organic light emitting layer on the upper surface of the first electrode; and forming the second electrode on the upper surface of the barrier layer and the organic light emitting layer.

[0023] The method of manufacturing an organic light emitting display device may further include forming a protective substrate on the upper surface of a second protective layer that contains desiccant particles, after forming the second protective layer on top of a first protective layer that is substantially free of desiccant.

[0024] The first protective layer may be formed of a sealant on the upper surface of the second electrode.

[0025] The second protective layer may include a sealant and the desiccant particles.

[0026] The sealant of the second protective layer may be formed of a same epoxy-based resin as the sealant of the first protective layer.

[0027] The sealant of the second protective layer may be formed of a different epoxy-based resin from the sealant of the first protective layer.

#### BRIEF DESCRIPTION OF THE DRAWINGS

[0028] The above and other features of the present disclosure will be described in reference to certain exemplary embodiments depicted in the attached drawings in which:

[0029] FIG. 1 is a plan view of an organic light emitting display (OLED) device in accordance with a first exemplary embodiment of the present disclosure;

[0030] FIG. 2 is a cross-sectional view taken along line I-I' of FIG. 1;

[0031] FIG. 3 is a cross-sectional view of an organic light emitting display device in accordance with a second exemplary embodiment of the present disclosure;

[0032] FIG. 4 is a cross-sectional view of an organic light emitting display device in accordance with a third exemplary embodiment of the present disclosure; and

[0033] FIGS. 5A to 5M are cross-sectional views illustrating methods of manufacturing an organic light emitting display device in accordance with exemplary embodiments of the present disclosure.

#### DETAILED DESCRIPTION

[0034] Reference will now be made in detail to exemplary embodiments of the present disclosure, depictions of which are illustrated in the accompanying drawings, wherein like reference numerals refer to generally alike elements through-

out. The embodiments are described below in order to explain the present disclosure by referring to the figures.

[0035] Hereinafter, exemplary embodiments of the present disclosure will now be described in detail with reference to FIGS. 1 to 5M. In the drawings, the thickness of layers and regions may be exaggerated for purpose of illustrative clarity.

[0036] FIG. 1 is a plan view of a first organic light emitting display (OLED) device in accordance with the present disclosure, and FIG. 2 is a cross-sectional view taken along line I-I' of FIG. 1.

[0037] Referring to FIGS. 1 and 2, the OLED device includes an organic light emitting pixel unit 45 (FIG. 2) formed on a transparent substrate 40 and including a gate line 50, a data line 60, a power line 70, a first thin film transistor (switching TFT) 80, a second thin film transistor (driving TFT) 110, a first electrode 143, an organic light emitting layer 160, and a second electrode 145. As seen in FIG. 2, the second electrode 145 is disposed above the first electrode 143 (e.g., a light transmitting electrode 143 such as made of ITO) and the organic light emitting layer 160 is sandwiched between them. The OLED device of the present disclosure also includes first and second protective layers 210 and 220, and a protective substrate 240. As will be detailed below, the first protective layers 210 is substantially free of desiccant particles while the second protective layer 220 includes such particles.

[0038] The substrate 40, on which a plurality of pixel units are arranged in a matrix form, may be formed of a transparent and electrically insulating material such as glass or plastic so that light transmits through the pixels.

[0039] The gate line 50 supplies a gate signal to the switching TFT 80, the data line 60 supplies a data signal to the switching TFT 80, and the power line 70 supplies a power signal to the driving TFT 110.

[0040] The switching TFT 80 is turned on when the gate line 50 is supplied with an activating gate signal so that the switching TFT 80 is rendered conductive to supply the data signal applied to the data line 60 to a storage capacitor Cst and a second gate electrode 111 of the driving TFT 110. For this purpose, the switching TFT 80 includes a first gate electrode 81 connected to the gate line 50, a first source electrode 83 connected to the data line 60, a first drain electrode 85 facing the first source electrode 83 and connected to a second gate electrode 111 of the driving TFT 110 and the storage capacitor Cst, and a first semiconductor pattern 90 defining a channel portion between the first source electrode 83 and the first drain electrode 85. The first semiconductor pattern 90 includes a first active layer 91 overlapping the first gate electrode 81 with a second gate insulating layer 77 disposed therebetween, and a first ohmic contact layer 93 formed on the first active layer 91 except for the channel portion to form an ohmic contact with the first source electrode 83 and the first drain electrode 85. The first active layer 91 may be formed of polysilicon or other forms of silicon (e.g., amorphous). In one embodiment, the first semiconductor layer 91 is formed of amorphous silicon which is advantageous to the on-off operation in view of desired characteristics of the switching TFT 80 which requires excellent discrete on-off characteristics.

[0041] The driving TFT 110 controls electric current supplied from the power line 70 to an organic light emitting cell, which will be described later, in response to the data signal applied to the second gate electrode 111 thereof, thus adjusting the light emitting amount of the organic light emitting cell. For this, the driving TFT 110 includes the second gate

electrode **111** connected to the first drain electrode **85** through a connection electrode **141**, a second source electrode **113** connected to the power line **70**, a second drain electrode **115** facing the second source electrode **113** and connected to a first electrode **143** of the organic light emitting cell, and a second conductive pattern **120** forming a channel portion between the second source electrode **113** and the second drain electrode **115**. The connection electrode **141** is formed of the same material as the first electrode **143** on a planarization layer **130**. The connection electrode **141** connects the first drain electrode **85** of the switching TFT **80** exposed through a first contact hole **103** to the second gate electrode **111** of the driving TFT **110** exposed through a second contact hole **105**. The first contact hole **103** penetrates a passivation layer **95** and the planarization layer **130** to expose the first drain electrode **85**, and the second contact hole **105** penetrates the second gate insulating layer **77**, the passivation layer **95** and the planarization layer **130** to expose the second gate electrode **111**.

[0042] The second semiconductor pattern **120** includes a second active layer **121** overlapping the second gate electrode **111** with a first gate insulating layer **73** disposed therebetween, and a second ohmic contact layer **123** formed on the second active layer **121** except for the channel portion to form an ohmic contact with the second source electrode **113** and the second drain electrode **115**. Such a second active layer **121** may be formed of amorphous silicon for example.

[0043] The second active layer **121** may alternatively be formed of polysilicon in view of the desired operating characteristics of the driving TFT **110** in which an electric current flows continuously during the frame-long light emission period of the organic light emitting cell.

[0044] The second gate electrode **111** of the driving TFT **110** overlaps the power line **70** with the second gate insulating layer **77**, thus forming the storage capacitor Cst. Such a storage capacitor Cst helps to supply a constant current to the driving TFT **110** by maintaining the gate **111** of the driving TFT **110** with the charged voltage of the storage capacitor Cst until a data signal of the next frame is supplied so that the organic light emitting cell maintains the light emission, even though the switching TFT **80** is turned off in the interim.

[0045] The organic light emitting cell includes the first electrode **143** formed of a transparent conductive material on the planarization layer **130**, an organic light emitting layer **160** including an emissive layer formed on the first electrode **143**, and a second electrode **145** formed on the organic light emitting layer **160**. Although not shown in detail, the organic light emitting layer **160** includes a hole injection layer, a hole transport layer, an optically emissive layer, an electron transport layer, and an electron injection layer, stacked in the recited order on the upper surface of the first electrode **143**. The emissive layer may be formed in a triple layer structure in which emissive layers displaying red (R), green (G) and blue (B) colors are sequentially stacked, or in a double layer structure in which emissive layers having a complementary color relationship are stacked, or in a single layer structure composed of an emissive layer emitting a white color. Accordingly, the emissive layer provided in the organic light emitting layer **160** emits light in accordance with (e.g., in proportion to) the amount of the current applied to the second electrode **145** and the light of the organic light emitting layer **160** is transmitted toward a color filter **200** by way of the first electrode **143**.

[0046] The first electrode **143** faces the second electrode **145** with the organic light emitting layer **160** disposed therebetween and formed every sub-pixel region. The first electrode **143** is formed independently in each sub-pixel region on the planarization layer **130**. The first electrode **143** is coupled to the second drain electrode **115** of the driving TFT **110** exposed by a third contact hole **107** formed by etching the first and second gate insulating layers **73** and **77**, the passivation layer **95**, and the planarization layer **130**. The first electrode **143** may be formed of a transparent conductive material such as indium tin oxide (ITO), indium zinc oxide (IZO), tin oxide (TO), or indium tin zinc oxide (ITZO).

[0047] A barrier layer **150** is formed on the upper surface of the connection electrode **141** connected to the planarization layer **130**. The barrier layer **150** is formed of an organic material to serve as an insulating layer. The barrier layer **150** is patterned (e.g., opened up near hole **107**) to expose the first electrode **143** such that the organic light emitting layer **160** is positioned on the upper surface of the first electrode **143**.

[0048] The second electrode **145** may be formed of aluminum (Al), magnesium (Mg), silver (Ag), or calcium (Ca) having excellent electron transport capability and good reflection performance.

[0049] The color filter **200** is formed to overlap the organic light emitting layer **160** generating white light on the upper surface of the passivation layer **95**. Accordingly, the color filter **200** displays red (R), green (G) and blue (B) colors using the white light produced from the organic light emitting layer **160**. The R, G or B light generated from the color filter **200** is emitted to the outside through the transparent substrate **40**.

[0050] The first protective layer **210** is formed to extend above and across the overall surface of the substrate **40**. In one embodiment, the first protective layer **210** is formed of an epoxy-based conformal sealant in order to prevent moisture and/or oxygen from penetrating from the outside and to protect the organic light emitting pixel unit **45** from various impacts. For example, the epoxy-based sealant may be formed of at least one member selected from the group consisting of bisphenol type epoxy resin, epoxidized butadiene resin, fluorine type epoxy resin, and novolac type epoxy resin.

[0051] The first protective layer **210** has a thickness greater than a step height of the second electrode **145** formed by the barrier layer **150** in order to reduce the step height, and the upper surface thereof is formed substantially planar (horizontally). The reason for this is to eliminate any space in which moisture or gas, which can cause damage to the organic light emitting layer **160** might be trapped due to respective layers to be stacked later on top of barrier layer **150** during mass production manufacture.

[0052] The second protective layer **220** is formed on the overall surface of the substrate **40** over the first protective layer **210**. Like the first protective layer **210**, the second protective layer **220** is formed of an epoxy-based sealant in order to prevent moisture or oxygen from penetrating from the outside. For example, the epoxy-based sealant may be formed of at least one member selected from the group consisting of bisphenol type epoxy resin, epoxidized butadiene resin, fluorine type epoxy resin, and novolac type epoxy resin.

[0053] However, unlike the first protective layer **210**, the second protective layer **220** comprises desiccant particles **230** (e.g., of average diameter of 5 microns) for absorbing moisture, distributed uniformly across the overall surface of the substrate **40**. The desiccant particles **230** act as fillers for removing moisture that manages to penetrate from the out-

side. For example, the desiccant particles **230** may be formed of one or more moisture absorbing materials such as talc, which do not exhibit any substantial swelling property when exposed to water or organic solution. Moreover, silica gel may be included as the desiccant member **230**. In this case, the desiccant particles **230** should have a thickness (measured vertically in FIG. 2) of a size smaller than the thickness of the second protective layer **220** (or vice versa, the second protective layer **220** should have a thickness equal to or greater than the normally largest ones of the desiccant particles expected to be found in the first protective layer **210**). For example, the largest normal ones of the desiccant particles **230** may have a size (e.g., diameter) of less than about 5  $\mu\text{m}$ , when the second protective layer **220** has a thickness of about 20  $\mu\text{m}$ .

[0054] The first and second protective layers **210** and **220** are structured to prevent an electrical failure from occurring in which the second electrode **145** is spot depressed into shorting contact with the first electrode **143**, due to a depression force exerted by an overlying desiccant member **230** of large size (overlying in FIG. 2), of which description will be given in connection with the protective substrate **240** below.

[0055] The protective substrate **240** is positioned on the upper surface of the second protective layer **220** to protect the organic light emitting pixel unit **45** from an external impact. The protective substrate **240** helps to prevent moisture or oxygen from penetrating from the outside together with the first and second protective layers **210** and **220**. Such a protective substrate **240** may be formed of a transparent insulating material such as glass or plastic, the same as the substrate **40**. The material of the protective substrate **240** is not limited to glass or plastic, but may be formed of various other materials such as an organic, inorganic or metallic material.

[0056] The protective substrate **240** is compressively bonded to the second protective layer **220**. The protective substrate **240** pressurizes the second protective layer **220** during the assembly process, thus potentially causing the depression of an underlying layer by particles of the desiccant members population **230** if the intervening first protective layer **210** were not present. However, at this time, the first protective layer **210** formed below the bottom of the second protective layer **220** acts to relieve the stress and strain of spot depressions caused by large ones of the desiccant particles **230**, thus preventing the undesirable spot depression of the second electrode **145** into shorting contact with the first electrode **143**. Accordingly, it is possible to prevent an electrical failure caused by the contact between the second electrode **145** and the first electrode **143**.

[0057] In the following, the first and second protective layers **210** and **220** in accordance with the exemplary embodiments of the present disclosure will be described in more detail.

[0058] In the first exemplary embodiment of the OLED device in accordance with the present disclosure, the first protective layer **210** and the second protective layer **220**, disposed between the organic light emitting pixel unit **45** and the protective substrate **240**, are formed of a same material except that the first protective layer **210** is substantially free of large desiccant particles **230** whereas the second protective layer **220** has such particles **230** substantially uniformly distributed throughout. For example, the first protective layer **210** and the second protective layer **220** may be formed of a sealant made of any one member selected from the group consisting of bisphenol type epoxy resin, epoxidized butadiene resin, fluorine type epoxy resin, and novolac type epoxy

resin. And as mentioned, the second protective layer **220** further includes the desiccant particles **230** such as talc. The first protective layer **210** serves as a stress buffering layer for preventing damage to the organic light emitting pixel unit **45** from an external impact and relieving the pressure from the top. The second protective layer **220** bonds to the protective substrate **240** and serves as a desiccant layer for preventing deeper penetration of moisture which manages to enter from the outside through, for example, the protective substrate **240**.

[0059] FIG. 3 is a cross-sectional view of an OLED device in accordance with a second exemplary embodiment. The same elements as those shown in FIGS. 2 and 3 are identified by the same reference numerals and descriptions of unchanged ones will be omitted.

[0060] As shown in FIG. 3, in the OLED device in accordance with the second exemplary embodiment, the first protective layer **210** and the second protective layer **220**, disposed between the organic light emitting pixel unit **45** and the protective substrate **240**, are formed of different materials. For example, the first protective layer **210** and the second protective layer **220** are formed of different epoxy-based sealants. Moreover, the second protective layer **220** further includes the desiccant particles **230** while the first protective layer **210** is substantially free of any or of desiccant particles like **230**. That is, the first protective layer **210** is formed of a first sealant, and the second protective layer **220** is formed of a different second sealant as well as including the desiccant particles **230**.

[0061] FIG. 4 is a cross-sectional view of an OLED device in accordance with a third exemplary embodiment. The same elements as those shown in FIGS. 2 and 4 are identified by the same reference numerals and descriptions of unchanged ones will be omitted.

[0062] As shown in FIG. 4, in the OLED device in accordance with the third exemplary embodiment, the second protective layer **220** including the desiccant particles **230** is formed on the upper surface of the second electrode **145**. Here, the second protective layer **220** is formed of an epoxy-based sealant but it has a nonuniform distribution of desiccant particles **230** in the vertical direction such that larger desiccant particles **230** appear near the top and essentially no desiccant particles (or only very small diameter ones) appear near the bottom of layer **220**. In one example, the second protective layer **220** may be formed of a sealant made of any one member selected from the group consisting of bisphenol type epoxy resin, epoxidized butadiene resin, fluorine type epoxy resin, and novolac type epoxy resin.

[0063] Moreover, as mentioned the desiccant particles **230** are distributed vertically so as to be spaced apart from the second electrode **145** at least at predetermined intervals in the second protective layer **220**. Especially, the desiccant particles **230** in the second protective layer **220** on the upper surface of the organic light emitting cell are disposed at a predetermined height from the second electrode **145** so that the desiccant-free or desiccant-light bottom portion of layer **220** functions as a buffer against excessive spot deformation of the second electrode **145**. In one case, the desiccant particles **230** may be arranged at a height such that the desiccant particles **230** do not cause a depression of the second electrode **145** due to the pressure from the top. For example, the second protective layer **220** is formed such that the desiccant particles **230** are distributed at a height of at least about 5  $\mu\text{m}$  from the second electrode **145**. During the formation of the second protective layer **220**, shrinkage of about 5  $\mu\text{m}$  may

occur through a curing process. The shrinkage of the second protective layer 220 makes the desiccant particles 230 to be close to the surface of the second electrode 145. Accordingly, the desiccant particles 230 included in the second protective layer 220 may be distributed at a height of at least about 5  $\mu\text{m}$  from the second electrode 145.

[0064] Meanwhile, if a step height of more than about 5  $\mu\text{m}$  is formed in the second electrode 145 by the barrier layer 150 disposed therebelow, the desiccant particles 230 may be distributed at a height within about 5  $\mu\text{m}$  from the second electrode 145 on the barrier layer 150. Since the desiccant particles 230 disposed on the upper surface of the barrier layer 150 do not cause the depression of the second electrode 145 in that stepped up region, it is allowed that the desiccant particles 230 are positioned within about 5  $\mu\text{m}$  or less.

[0065] Next, a method of manufacturing an OLED device in accordance with the present disclosure will be described with reference to FIGS. 5A to 5M.

[0066] The method of manufacturing an OLED device in accordance with the present disclosure includes forming an organic light emitting pixel unit 45 on a transparent substrate 40, where the method includes forming a first protective layer 210 on the upper surface of the organic light emitting pixel unit 45 where the first protective layer 210 is substantially free of any desiccant particles 230, and forming a second protective layer 220 in which desiccant particles 230 are distributed uniformly or on a vertically graduated basis in the first protective layer 210.

[0067] First, the process of forming the organic light emitting pixel unit 45 will be described with reference to FIG. 5A below.

[0068] As shown in FIG. 5A, a second semiconductor pattern 120 including a second active layer 121 of a driving TFT 110 and a second ohmic contact layer 123 is formed on a substrate 40. The second active layer 121 and the second ohmic contact layer 123 are formed of polysilicon in view of the desired characteristics of the driving TFT 110. The process of forming the second active layer 121 will be described in more detail below. First, amorphous silicon and  $n^+$  doped amorphous silicon are deposited on the overall surface of the substrate 40 in a uniform thickness and then re-crystallized into polycrystalline form by laser irradiation or solid phase crystallization using heat and a magnetic field. The solid phase crystallization is typically used for the crystallization of a large-area substrate. The poly-crystallized silicon layer is patterned by photolithography and etching processes, thus forming the second active layer 121 and the second ohmic contact layer 123 as shown in FIG. 5A.

[0069] Subsequently, as shown in FIG. 5B, a driving metal pattern including a power line 70, a second source electrode 113 and a second drain electrode 115 is formed thereon. More specifically, a conductive metal is deposited on the overall surface of the substrate 40 by a sputtering method and patterned by photolithography and etching processes, thus forming the power line 70, the second source electrode 113 and the second drain electrode 115. At this time, the second ohmic contact layer 123 which is not covered but exposed by the second source electrode 113 and the second drain electrode 115 is removed by an etching process to form a channel formed of amorphous silicon only.

[0070] Next, a first gate insulating layer 73 is formed on the overall surface of the substrate 40. The first gate insulating layer 73 is formed by depositing an inorganic insulating material such as silicon oxide ( $\text{SiO}_x$ ), silicon nitride ( $\text{SiN}_x$ ), or the

like on the overall surface of the substrate 40 by a deposition method such as plasma enhanced chemical vapor deposition (PECVD).

[0071] As shown in FIG. 5C, a gate metal pattern including a first gate electrode 81, a second gate electrode 111 and a gate line 50 is formed on the first gate insulating layer 73. Moreover, a second gate insulating layer 77 is formed on the upper surface of the gate metal pattern.

[0072] More specifically, a conductive metal is deposited on the upper surface of the first gate insulating layer 73 by a sputtering method and then patterned by photolithography and etching processes, thus forming the first and second gate electrodes 81 and 111. At this time, the gate line 50 is formed simultaneously with the formation of the first gate electrode 81.

[0073] Subsequently, the second gate insulating layer 77 is deposited on the overall surface of the substrate 40 on which the first and second gate electrodes 81 and 111 are formed. Since the second gate insulating layer 77 is formed in the same manner as the first gate insulating layer 73, a detailed description will be omitted.

[0074] As shown in FIG. 5D, a first semiconductor pattern 90 including a first active layer 91 and a first ohmic contact layer 93 is formed on the second gate insulating layer 77. The first active layer 91 and the first ohmic contact layer 93 are formed of amorphous silicon in view of the desired characteristics of a switching TFT 80. Accordingly, an amorphous silicon layer is deposited on the substrate 40 and patterned by photolithography and etching processes, not subjected to a re-crystallization process, thus forming the first active layer 91 and the first ohmic contact layer 93.

[0075] Next, as shown in FIG. 5E, a data metal pattern including a data line 60, a first source electrode 83 and a first drain electrode 85 is formed on the substrate 40 on which the first semiconductor pattern 90 is formed. Since the process of forming the first source electrode 83 and the first drain electrode 85 is the same as that of the second source electrode 113 and the second drain electrode 115, a detailed description will be omitted.

[0076] Subsequently, as shown in FIG. 5F, a passivation layer 95 is formed on the substrate 40 on which the data metal pattern is formed, and a color filter 200 including R, G and B color filter elements is formed on the passivation layer 95.

[0077] The passivation layer 95 is formed by stacking an inorganic insulating material such as silicon oxide ( $\text{SiO}_x$ ), silicon nitride ( $\text{SiN}_x$ ), or the like on the substrate 40 on which the data metal pattern is formed. The color filter 200 is formed in such a manner that R, G and B pigments are stacked in each sub-pixel on the substrate 40, on which the passivation layer 95 is formed, and then patterned by photolithography and etching processes.

[0078] Then, as shown in FIG. 5G, a planarization layer 130 including first to third contact holes 103, 105 and 107 is formed on the upper surface of the passivation layer 95 and the color filter 200.

[0079] The planarization layer 130 may be formed by a spin coating or spinless coating method on the substrate 40 on which the passivation layer 95 is formed. The first to third contact holes 103, 105 and 107 are then formed by selectively patterning at least two layers of the first and second gate insulating layers 73 and 77, the passivation layer 95, and the planarization layer 130 by photolithography and etching processes. The first contact hole 103 penetrates the passivation layer 95 and the planarization layer 130 to expose the first

drain electrode **85** of the switching TFT **80**. The second contact hole **105** penetrates the second gate insulating layer **77**, the passivation layer **95** and the planarization layer **130** to expose the second gate electrode **111** of the driving TFT **110**. The third contact hole **107** penetrates the first and second gate insulating layers **73** and **77**, the passivation layer **95** and the planarization layer **130** to expose the second drain electrode **115** of the driving TFT **110**.

[0080] Next, as shown in FIG. 5H, a transparent conductive pattern including a connection electrode **141** and a first electrode **143** is formed on the substrate **40** on which the planarization layer **130** is formed.

[0081] The transparent conductive pattern is formed on the substrate **40**, on which the planarization layer **130** is formed, by a deposition method such as sputtering and then patterned by photolithography and etching processes. The transparent conductive layer may comprise ITO, IZO, TO, and/or ITZO.

[0082] Subsequently, as shown in FIG. 5I, a barrier layer **150** is formed on the substrate **40** on which the planarization layer **130** and the connection electrode **141** are formed, and an organic light emitting layer **160** is formed on an upper surface of the first electrode **143**.

[0083] The barrier layer **150** is formed in such a manner that an organic insulating material is deposited on the upper surface of the planarization layer **130** and the transparent conductive pattern and then patterned by photolithography and etching processes. At this time, the barrier layer **150** is patterned to define a pixel through-hole through which the first electrode **143** is exposed.

[0084] Next, the organic light emitting layer **160** is formed on the pixel hole through which the first electrode **143** is exposed. An emissive layer included in the organic light emitting layer **160** may be formed in a triple layer structure in which emissive layers displaying R, G and B are sequentially stacked, in a double layer structure in which emissive layers having a complementary color relationship are stacked, or in a single layer structure composed of emissive layers displaying R, G and B colors, respectively.

[0085] As shown in FIG. 5J, a second electrode **145** is formed on the substrate **40** on which the organic light emitting layer **160** is formed.

[0086] The second electrode **145** may be formed by depositing a metal layer on the upper surface of the barrier layer **150** and the organic light emitting layer **160**. The second electrode **145** is formed of Al, Mg, Ag, or Ca having excellent reflectivity in order to reflect light incident from the organic light emitting layer **160**.

[0087] Next, the process of forming the first protective layer **210** on the organic light emitting pixel unit **45** and the process of forming the second protective layer **220** on the first protective layer **210** will be described with reference to FIGS. 5K and 5L below.

[0088] As shown in FIG. 5K, the first protective layer **210** is formed on the substrate **40** on which the second electrode **145** is formed.

[0089] The first protective layer **210** is formed on the overall surface of the substrate **40** over the second electrode **145**. The first protective layer **210**, which is substantially free of any or of desiccant particles, is formed on the upper surface of the second electrode **145** using a sealant made of any one selected from the group consisting of bisphenol type epoxy resin, epoxidized butadiene resin, fluorine type epoxy resin, and novolac type epoxy resin. Moreover, the first protective layer **210** is formed with a thickness greater than a step height

of the second electrode **145** formed by the barrier layer **150** to reduce the step height, and the upper surface thereof is formed horizontally to prevent moisture or gas from penetrating between respective layers to be stacked or bonded later. At this time, the first protective layer **210** is formed on the upper surface of the second electrode **145** by a screen printing method or a dispensing method in view of the viscosity of the sealant.

[0090] Subsequently, as shown in FIG. 5L, the second protective layer **220** is formed on the substrate **40** on which the first protective layer **210** is formed.

[0091] The second protective layer **220** is formed on the overall surface of the substrate **40** over the first protective layer **210**. The second protective layer **220** is formed of an epoxy-based sealant, like the first protective layer **210**. Moreover, the second protective layer **220** comprises the large-sized desiccant particles **230** such as talc, silica gel, or other non-swelling desiccant particles usable to prevent the further penetration of moisture that managed to get in from the outside. The second protective layer **220** is formed such that the desiccant particles **230** are distributed uniformly in the horizontal directions across the overall surface of the substrate **40**. Furthermore, the second protective layer **220** is formed to have a planar top surface and/or a constant thickness such that a protective substrate **240** can be bonded thereto accurately later.

[0092] The method of manufacturing an OLED device in accordance with the present disclosure further includes bonding the protective substrate **240**, which will be described with reference to FIG. 5M below.

[0093] As shown in FIG. 5M, the protective substrate **240** is bonded to the upper surface of the second protective layer **220**. The protective substrate **240** is formed of an insulating material such as glass or plastic, like the substrate **40**. The protective substrate **240** is bonded thereto by pressurizing the second protective layer **220**. After bonding the protective substrate **240** to the second protective layer **220**, the first protective layer **210** and the second protective layer **220** are cured to finish the OLED device.

[0094] The process of forming the first and second protective layers **210** and **220** in accordance with the present disclosure is not limited to those described above with reference to FIGS. 5K and 5L. For example, the first protective layer **210** may be formed on the substrate **40** on which the organic light emitting pixel unit **45** is formed, the second protective layer **220** may be formed on the protective substrate **240**, and then the first and second protective layers **210** and **220** may be bonded to each other. In this case, the denser desiccant particles **230** included in the second protective layer **220** are slowly settled down and move onto the surface of the protective substrate **240**. With such desiccant particles **230** moving onto the surface of the protective substrate **240**, it is possible to prevent the situation where the larger desiccant particles in the second protective layer **220** damage the second electrode **145** by pressurizing of the first protective layer **210** while the second protective layer **220** is bonded to the first protective layer **210**.

[0095] Subsequently, the first protective layer **210** formed on the substrate **40** and the second protective layer **220** formed on the protective substrate **240** are bonded to each other and then cured.

[0096] Examples of materials used in forming the first protective layer **210** and the second protective layer **220** in the

method of manufacturing an OLED device in accordance with the present disclosure will be described below.

**[0097]** According to one method of manufacturing an OLED device in accordance with a first exemplary embodiment of the present disclosure, the first protective layer **210** and the second protective layer **220** are formed using a same sealant material. For example, the first protective layer **210** is formed of a sealant made of any one member selected from the group consisting of bisphenol type epoxy resin, epoxidized butadiene resin, fluorine type epoxy resin, and novolac type epoxy resin. The second protective layer **220** including the desiccant particles **230** such as talc, silica gel, etc is formed of the same sealant as the first protective layer **210** on the upper surface of the first protective layer **210**.

**[0098]** According to a second method of manufacturing an OLED device in accordance with a second embodiment of the present disclosure, the first protective layer **210** and the second protective layer **220** are formed using different sealant materials. For example, the first protective layer **210** is formed of a sealant made of any one selected from the group consisting of bisphenol type epoxy resin, epoxidized butadiene resin, fluorine type epoxy resin, and novolac type epoxy resin. The second protective layer **220** including the desiccant particles **230** is formed of a sealant different from that of the first protective layer **210** on the upper surface of the first protective layer **210**.

**[0099]** As described above, the OLED device in accordance with the present disclosure includes the first protective layer and the second protective layer including the desiccant particles formed on the upper surface of the organic light emitting diode using an epoxy-based sealant. The first protective layer is formed with a predetermined thickness on the upper surface of the second electrode of the organic light emitting pixel unit to prevent or reduce excessive spot depression of the underlying layer caused by the desiccant particles included in the second protective layer. Accordingly, it is possible to prevent an electrical failure in which the second electrode is spot depressed into shorting contact with the first electrode, and a pixel defect in which pixels do not emit light.

**[0100]** Although the present disclosure has been described with reference to certain exemplary embodiments thereof, it will be understood by those skilled in the art that a variety of modifications and variations may be made to the present disclosure without departing from the spirit or scope of the present teachings.

What is claimed is:

1. An organic light emitting display device comprising:
  - an organic light emitting pixel unit having a first electrode, an organic light emitting layer, and a second electrode, the organic light emitting pixel unit being integrally formed on a substrate;
  - a first protective layer that is substantially free of desiccant particles being formed on the upper surface of the second electrode; and
  - a second protective layer, including desiccant particles being formed on the first protective layer.
2. The organic light emitting display device of claim 1, further comprising a protective substrate compressively bonded to the second protective layer.
3. The organic light emitting display device of claim 1, wherein the first protective layer is formed of a sealant that inhibits passage of moisture therethrough.

4. The organic light emitting display device of claim 3, wherein the second protective layer including the desiccant particles is formed of a sealant that inhibits passage of moisture therethrough.

5. The organic light emitting display device of claim 4, wherein the sealant of the first protective layer is formed of a same material as the sealant of the second protective layer.

6. The organic light emitting display device of claim 5, wherein the sealant of the first protective layer is formed of a same epoxy-based resin as the sealant of the second protective layer.

7. The organic light emitting display device of claim 4, wherein the sealant of the first protective layer is formed of a different material from the sealant of the second protective layer.

8. The organic light emitting display device of claim 7, wherein the sealant of the first protective layer is formed of a different epoxy-based resin from the sealant of the second protective layer.

9. The organic light emitting display device of claim 1, wherein the first protective layer is has a thickness substantially greater than a largest expected diameter of the desiccant particles in the second protective layer.

10. The organic light emitting display device of claim 1, wherein the desiccant particles are formed of at least one of a talc and a silica gel.

11. An organic light emitting display device comprising:
  - an organic light emitting pixel unit having a first electrode, an organic light emitting layer, and a second electrode, the pixel unit being formed on a substrate; and
  - a protective layer, including desiccant particles, formed on the upper surface of the second electrode, wherein the desiccant particles are spaced by at least 5  $\mu\text{m}$  apart from the upper surface of the second electrode.

12. The organic light emitting display device of claim 11, further comprising a protective substrate bonded to the substrate with the protective layer disposed therebetween.

13. A method of manufacturing an organic light emitting display device, the method comprising:

- forming an organic light emitting pixel unit integrally on a substrate, the organic light emitting pixel unit including a driving thin film transistor, a switching thin film transistor, a first electrode, an organic light emitting layer, and a second electrode,

- forming a first protective layer on an upper surface of the organic light emitting pixel unit where the first protective layer is substantially devoid of desiccant particles; and

- forming a second protective layer in which desiccant particles are distributed within the second protective layer, where the second protective layer is formed on an upper surface of the first protective layer.

14. The method of claim 13, wherein forming the organic light emitting pixel unit comprises:

- forming the driving thin film transistor and the switching thin film transistor on the substrate;

- forming a passivation layer to cover the driving thin film transistor and the switching thin film transistor, and a color filter on the upper surface of the passivation layer;

- forming a planarization layer including first to third contact holes on the upper surface of the passivation layer and the color filter;

forming a transparent conductive pattern including a connection electrode and the first electrode on the upper surface of the planarization layer;

forming a barrier layer on the upper surface of the planarization layer and the connection electrode, and the organic light emitting layer on the upper surface of the first electrode; and

forming the second electrode on the upper surface of the barrier layer and the organic light emitting layer.

**15.** The method of claim **14**, further comprising compressively bonding a protective substrate on the upper surface of the second protective layer, after forming the second protective layer.

**16.** The method of claim **14**, wherein the first protective layer is formed of an anti-moisture sealant and is disposed on the upper surface of the second electrode.

**17.** The method of claim **16**, wherein the second protective layer comprises an anti-moisture sealant and desiccant particles distributed therein.

**18.** The method of claim **17**, wherein the sealant of the first protective layer is formed of a same epoxy-based resin as the sealant of the second protective layer.

**19.** The method of claim **17**, wherein the sealant of the first protective layer is formed of a different epoxy-based resin from the sealant of the second protective layer.

\* \* \* \* \*

专利名称(译)	具有干燥剂层的有机发光显示装置及其制造方法		
公开(公告)号	<a href="#">US20080238303A1</a>	公开(公告)日	2008-10-02
申请号	US12/014459	申请日	2008-01-15
[标]申请(专利权)人(译)	李东WON 金勋 KOO WON HOE 李尚禹 崔贞MI		
申请(专利权)人(译)	李东WON 金勋 KOO WON-HOE 李尚禹 崔贞-MI		
当前申请(专利权)人(译)	李东WON 金勋 KOO WON-HOE 李尚禹 崔贞-MI		
[标]发明人	LEE DONG WON KIM HOON KOO WON HOE LEE SANG WOO CHOI JUNG MI		
发明人	LEE, DONG- WON KIM, HOON KOO, WON-HOE LEE, SANG-WOO CHOI, JUNG-MI		
IPC分类号	H01L27/28 H01J9/02		
CPC分类号	H01L27/3244 H01L51/5237 H01L51/5259 H01L51/5246 H01L51/5253 H01L2227/323		
优先权	1020070031427 2007-03-30 KR		
外部链接	<a href="#">Espacenet</a> <a href="#">USPTO</a>		

#### 摘要(译)

一种有机发光显示装置，包括：有机发光像素单元，具有形成在基板上的第一电极，有机发光层和第二电极；其中第一防潮保护层形成在第二电极的上表面上；在所述第一保护层的上表面上形成第二防潮保护层，其中所述第二保护层包括直径包括预定最大直径的干燥剂颗粒，并且其中所述第一保护层基本上不含具有所述预定最大直径的干燥剂颗粒最大直径或更大，并且第一保护层的厚度基本上大于预定的最大直径。

